

SERVICE MANUAL

RT6500 VHF RADIO TELEPHONE

)

)

INSTRUCTIONS FOR PR6500

Programming kit for the RT6500

- b **FIRST COUNTRY.** Use the space bar to cycle through the list of available options. Note: when the Scandinavian Modes are enabled an extra 3 channels become available.
- c **START UP CHANNEL.** Type in channel number, e.g. 06, 16, 83, etc., or PO1 for a private channel or "<space>0" for channel 0.
- d **SELCALL NUMBER.** Enter 5 digit number followed by a carriage return. (Note: this is the only instruction that needs terminating in this way).
- e **CHANNEL ATTRIBUTES.** When selected all the attributes will be flashing (reading left to right these are: International Mode only, USA mode only, Scan barred, Transmit barred, Lower power mode and Channel Mode consisting of: - (off), S (simplex), D (Duplex), R (reverse duplex). To change the individual attribute press the space bar. This will highlight the channel mode attribute. Use the left and right cursor keys to move through the attributes and the space bar to change the attribute. To leave the selected channel move the cursor past the end of the attributes.
- f **Leaving this set-up page.** If carriage return is pressed one of two things will happen. If private channels are not allowed the computer will down load the data to the radio. A message is displayed while this is happening. Do not turn off the radio until the main menu is displayed again.

If private channels are allowed a new set-up page will be displayed, showing the 16 available private channels, their attributes, frequencies and channel number if known.

To set up a private channel set the attributes as in the first page menu, then cursor to either frequency or the channel number. The Rx or Tx frequency may be entered to six digits, the decimal point being optional, or the two digit channel number. The remaining columns will be automatically completed by the programme.

When all the private channels required are entered press carriage return to down load the set-up to the radio.

INSTRUCTIONS FOR PR6500

SIMRAD

A KONGSBERG Company

Programming kit for the RT6500

EQUIPMENT NEEDED:

PR6500 Programming Software and Interface

IBM compatible computer

Optionally an EPSON compatible printer

SIMRAD-NAVICO LIMITED
STAR LANE, MARGATE, KENT
CT9 4NP UNITED KINGDOM
TELEPHONE +44 (0)1843 290290
FAX +44 (0)1843 290471

USING THE SOFTWARE:

- 1 Fit the 9-way D-type connector to the serial port allocated as COM1 of the computer. Connect the round socket to the microphone connector of the RT6500 and turn the radio on.
- 2 The software may be run directly from the supplied floppy disc or copied to the hard disc. There are no specialist installation routines. Type NVMSETUP to run the programme.
- 3 The opening page of the programme has brief instructions on operation of the software plus a question as to whether a printer is attached to your computer. An EPSON compatible printer is supported to output the private channel information. Answer Y or N to this question in order to move on to the main menu.
- 4 The main menu allows a choice of sources for the data. Normally use "2" to read the data from the radio for modification. The default table will revert the radio to "ship" mode operation with all international channels enabled. Option 5 allows a cloning operation to be carried out between two radios.
- 5 The main set-up page is displayed if 1 or 4 is selected. This shows all the configuration details allowed in the RT6500. On entry to this page the YES after SCANNING will be flashing. By using the cursor keys any of the options may be selected. The means of changing the set-up varies according to the option type.
 - a YES/NO. When this value is flashing type a Y or N to change the state (Note: when Base Station is enabled with Y the programme will automatically disable all the channels. Disabling Base Station mode will enable all channels in Ship mode).

Index To RT6500

1. Introduction to the RT6500
 - 1.1 Electronic Components
 - 1.2 Mechanical Components
 - 1.3 Selcall/BD version of the RT6500
 - 1.4 List of Product Variant (by Code)
2. Operating the RT6500
3. Assembly/Disassembly Instructions
 - 3.1 Radio Disassembly
 - 3.2 Fistmike Disassembly
 - 3.3 Telephone Handset Disassembly
4. Circuit Description
 - 4.1 Control board Circuit Description
 - 4.2 RX/TX Circuit Description
 - 4.3 RX/TX setup Procedure
 - 4.4 Selcall BD Circuit Description
5. Programming and Configuration
 - 5.1 RT6500S - Private Channel Programming
 - 5.2 Selcall/BD ID number programming.
6. Circuit/Mechanical Assembly Drawings
 - 6.1 PCB circuit diagrams
 - 6.2 Components Lists and layout for PCB's
 - 6.3 Mechanical assembly drawings
 - 6.4 Minimum Recommended spares stockholding.
7. Historical List of Modifications
 - 7.1 Historical list of electrical/mechanical modifications
 - 7.2 Historical list of S/W variations.
8. Trouble Shooting Guide
9. Update Sheets

RT6500 VHF Radio Telephone**1 Introduction**

The RT6500 is a compact Radio Telephone that incorporates an LCD display, and microprocessor control of channel selection and programming. The transmission module utilises thick film technology to ensure that maximum transmission power is maintained over periods of extended use. The receiver module incorporates high quality silicon FETs to reduce noise levels, and maintain high sensitivity.

The Main components of the RT6500 are :-

1.1 Electronics PCB's

- a) Control PCB - Drg. no. E00420 - Conventional mount (version 1)
 - Drg. no. E01309 - Early surface mount
 - Drg. no. E01169 - Surface mount (version 2)
- b) RX/TX PCB - Drg. no. E00425

1.2 Mechanical Components

- a) RT6500 Assy drawing - Drg no. E01425
- b) Fist Mike Assy drawing - Drg no. E00446
- c) Handset Assy drawing - Drg no. E00459

1.3 Selcall Compatible Versions Of the RT6500

The selcall version of the RT6500 allows direct connection into the telephone network in countries that support the system. Navico produce a number of versions of this product for compatibility with the local dialling system. These versions of the RT6500 feature modified handsets that incorporate the circuitry needed for the tone decoding of phone numbers. For details of the electronic and mechanical differences please refer to the following drawings :-

1) Electronics PCB's

- a) BD6500 handset - Drg no. E01656

2) Mechanical

a) BD handset Assy Drawing - Drg no. E01748

NOTE that the BD/Selcall handset plugs into a Version 2 (Surface Mount) control PCB (E01169). This control pcb is of a modular design, and SELCALL versions will be configured as such by altering the components fitted at the factory. See Selcall section of the main circuit description for details.

1.4 List of Current Product Variants**UK Variants**

RT6500 :F:A	UK MPRT1251 with fist mike
RT6500S:F:B	UK MPRT1251 Scan with fist mike
RT6500 :H:A	UK MPRT1251 with handset
RT6500S:H:B	UK MPRT1251 scan with handset
RT6500C:H:C	UK MPRT1251
RT6500B:F:M	UK Base Station with fist mike
RT6500B:H:M	UK Base station with handset
RT6500B:F:M37	UK Base station (chan 37) with fist mike
RT6500 :H:AZ	UK boat builders with handset.
RT6500 :F:AZ	UK boat builders with fistmike.
RT6500S:F:BZ	UK boat builders with fistmike.
RT6500S:H:BZ	UK boat builders with Handset.
RT6500S:H:U	UK
RT6500B:H:AI	UK Contract

French Variants

RT6500BD:T:JB	French Bi-Dir
RT6500BD:T:JW	French W.Indies
RT6500 :H:J	France
RT6500 :H:W	French contract
RT6500BD:T:SM	Maritime French W.Indies

Other Variants

RT6500 : :AC	Korea
RT6500 :F:A2M	Malta
RT6500 :F:AH	UAE
RT6500 :F:Q	Belgium
RT6500 :H:P	Holland
RT6500 :H:S	Spain
RT6500 :H:Q	Belgium
RT6500 :H:Y	Holland
RT6500R:H:Z	Germany
RT6500S:F:AB	Australia
RT6500S:F:AD	Austria
RT6500S:F:BX	Saudi Arabia
RT6500S:F:H	Canada
RT6500S:F:I	USA
RT6500S:F:R	Italy
RT6500S:F:T	New Zealand

RT6500S:H:AA	Iceland
RT6500S:H:AB	Australia
RT6500S:H:AD	Austria
RT6500S:F:AE	Singapore
RT6500S:H:AJ	Portugal
RT6500S:H:AK	Turkey
RT6500S:H:B2M	Malta
RT6500S:H:D	Denmark
RT6500S:H:E	Denmark
RT6500S:H:F	Norway
RT6500S:H:H	Canada
RT6500S:H:I	USA
RT6500S:H:K	Norway
RT6500S:H:L	Germany
RT6500S:H:N	Sweden
RT6500S:H:O	Sweden
RT6500S:H:R	Italy
RT6500S:H:T	New Zealand
RT6500S:H:V	HongKong
RT6500S:H:X	Finland
RT6500SC:H:NS	Sweden

2 Operating the RT6500

This service manual contains operating instruction only for those features of the RT6500 range that are not normally available to the end user (eg. channel programming). For details of the normal operation of the unit, included button assignments, connection to a power supply and aerial installation please refer to the RT6500 Operating Manual, E00472 ver2.

3 Assembly/Disassembly Instructions

3.1 Radio Disassembly

These disassembly instructions are applicable to the Version B RT6500 radios that have been available from 1990.

1) Release the four M4 screws that hold the top and bottom casing together. The Front panel will now also drop free. Care must be taken to avoid straining the wires that hold the three pieces of the casework together.

2) To disassemble the front panel first disconnect it from the main RX/TX board by un-plugging socket SK1. The PCB can be removed from the casework by un-plugging the speaker lead, removing the Four fixing screws, and de-soldering the six pins of the microphone socket. Care must be taken when de-soldering these pins as damage to the plated-through holes may render the board un-serviceable.

3) The main RX/TX board can be removed by releasing the seven Phillips screws that secure it to the bottom casing. During re-assembly ensure that the two ceramic capacitors that connect to the fixing screws are correctly re-positioned. Also ensure that there are insulating washers on these screws to prevent the 0v from the RX/TX board connecting to the casework and ruining the screening. Ensure however that there is a good connection between the PA and the PCB 0v via the copper screen as this IC gets its power from this connection.

4) Re-assembly is the reverse procedure.

3.1 Fistmike Disassembly

1) Remove the single Phillips screw securing the two halves of the moulding. The unit will separate from the bottom allowing the retaining clip at the top to release. Reassembly is the reverse procedure, but care must be taken to ensure that the microphone/speaker is seated correctly, and that the supply wires are not trapped.

3.1 Handset Disassembly

1) Remove the four Phillips screws that secure the front and rear handset mouldings. The hand set will now separate into three pieces revealing the interior components. Reassembly is the reverse procedure, but once again care must be taken that the supply wires are not trapped.

4 RT6500 Circuit description

The Navico RT6500 is a fully synthesised FM transceiver designed for the marine FM band. Drg E00534 shows a block diagram of the circuitry which is described in more detail below.

The circuitry is divided into two PCB's :-

1. Control P.C.B.
2. Rx/Tx P.C.B.

The RT6500 variants with SELCALL have an additional PCB (the BD6500 handset, drg no. E01656) that is described in section 4.

3. BD6500 Circuit description.

4.1 Control P.C.B. (E01169)

The control P.C.B. is attached to the front panel of the unit behind the controls and display. The circuit diagram for the control P.C.B is drawing number E01169 (see section 4.1).

IC1, a single chip microprocessor, interprets commands from the front panel controls and relays them to the RX/TX board. Switches S1 - S6 control the frequency of operation, the power of transmission, the mode of reception and the P.T.T operation.

A custom single phase LCD is driven from the microprocessor through a driver IC to give information regarding the status of operation (power, scan mode, channel of operation). Variable levels of back lighting can be selected for night time operation.

Scanning versions of the radio store data concerning the channel frequencies and mode of operation in non volatile memory to ensure that the data is not lost when the unit is disconnected from the ships supply. Non scanning radios have seven power up detector pads to configure the channel requirements.

Optional SELCALL is available for those national PTT's that support it. The Handset on this version contains a microprocessor that controls and filters the touch tone dialling protocol for this service.

The squelch and volume controls are connected via the control P.C.B. to the relevant circuitry on the Rx/Tx P.C.B. Audio from the loudspeaker can be inhibited when the telephone handset is lifted from its cradle.

Data from the microprocessor to the frequency synthesizer is sent as a synchronous 19 bit serial data stream with an enable signal immediately after the 19th bit.

Format of the 19 bit word is as follows :-

7 bits - A	10 bits - N	Two bit switching
-A.....-A	-N_N	Power select Rx/Tx

4.2 Rx/Tx PCB (E00425)

i) Synthesizer

The V.C.O. (grounded gate oscillator - TR14) oscillates at the frequency of transmission in transmit mode or the first local oscillator frequency (wanted signal frequency less 21.4 MHz) in receive mode. Switching the oscillator between transmit and receive frequencies is accomplished by pin diode D13. The oscillator is tuned by varactor diode D14.

The VCO output is buffered by TR13 and fed to a dual modulus prescaler IC5. The output of IC5 is fed to a specialised frequency synthesizer chip which houses the necessary frequency dividing circuitry, reference oscillator (12.8 MHz) and phase comparator.

Temperature compensation of the reference oscillator is provided by varicap D20 controlled by thermistor TH1. Compensation is only applied at high temperatures, the range being controlled by D21.

The synthesizer accepts serial data from the control PCB which in turn controls the divide ratio required for the particular frequency to be used. Phase comparison of the VCO signal with the reference oscillator is carried out at 12.5 KHz. The output of the phase detector is filtered by R90, R89, C138, C148, R92, C140, R95 and C154 to give the control voltage to varactor diode D14.

ii) Voltage supplies.

The majority of the circuitry operates from +8V regulated by REG1. Three +8V lines are used - pin 1 +8V at all times, pin 6 +8V transmit only, pin 8 +8V receive only. The audio amplifier IC3 operates from +12V as does the final output stage of the transmit amplifier and the voltage control transistor (TR10) for the penultimate transmit output stage. TR10 is not fitted to ver B units (serial No IC26724).

iii) Modulation.

The audio signal from the microphone is amplified by IC6b having been given a 6dB/Octave pre-emphasis by C135 and R81: C136 provides a high frequency roll-off point. The output of IC6b (pin 7) is fed through a diode limiting circuit (D15, D16) to a filter circuit R72, C131, R71, C128, R70, C130 and IC6a. VR3 controls the maximum modulation. The output of the filter (IC6 pin 1) is fed to the VCO and applied to varactor D12.

iv) Transmit amplification:

The output from the VCO is buffered by cascode TR11 and TR6, filtered by the double tuned circuit L21, C79, L23, C80 and fed to amplifier TR5. The output of TR5 is tuned (L20, C74, C75) and connected to drive transistor TR4. TR4 operates in class C and has only a nominal bias voltage. The output of TR4 is filtered and connected to a 25 watt class 'C' amplifier module. Power control is effected by varying the supply voltage to driver transistor TR4 and the first stage of the power module.

The output of the power module is fed via switching diode D2 and low pass filter ($f_o = 165$ MHz) L15, L14, L13, C55, C58, C54, C53, C157, C158, C160 to the antenna socket.

D1 protects the receiver from high voltages during transmit mode. The current to switch this on is fed through both D1 and D2.

v) Power control:

The r.f. level is monitored by C57, rectified by D5 and D6 and smoothed by C87 and R43, to provide a negative going DC voltage proportional to the transmit output power. VR1 and VR2 control a voltage pot-down which is fed to amplifier TR8 and then to the voltage control transistor TR10. This transistor controls the supply voltage to the module driver transistor TR4. TR9 provides temperature compensation for the circuit operation.

vi) Receiver front end, mixer and 1st I.F.

The incoming signal is filtered by a tuned couple L2, C3, L3, C4 and amplified by TR1. The signal is further filtered by tuned triple L4, C9, L6, C12, L7 C14 to significantly attenuate the image frequency and other out of band signals. TR2 mixes the received frequency with the local oscillator (from VCO buffer TR11, TR12) to convert the wanted signal to 21.4MHz. Crystal filter X2 and X3 provide at least 40dB of adjacent channel rejection. The signal is then fed to specialised I.F. chip IC1.

vii) 2nd I.F. Demodulation and audio.

The 21.4 MHz signal is mixed with 21.855 MHz (X4) to convert to the 2nd I.F. frequency of 455 KHz. Further filtering, giving at least 35 dB of adjacent channel rejection followed by limiting amplification takes place in the IF chip IC1. Demodulation takes place on quadrature coil L31. The recovered audio has high frequency (i.e. 455 KHz) removed by L10 and C26.

De-emphasis at 6dB/octave is achieved by R21 and C29 and the resulting audio signal is fed to both the headphone amplifier IC2b and audio power amplifier IC7. The volume control cuts the level of signal to the audio power amplifier only. The audio signal to both the headphone amplifier and power amplifier can be squelched by grounding the junction of C30, C31 and C35.

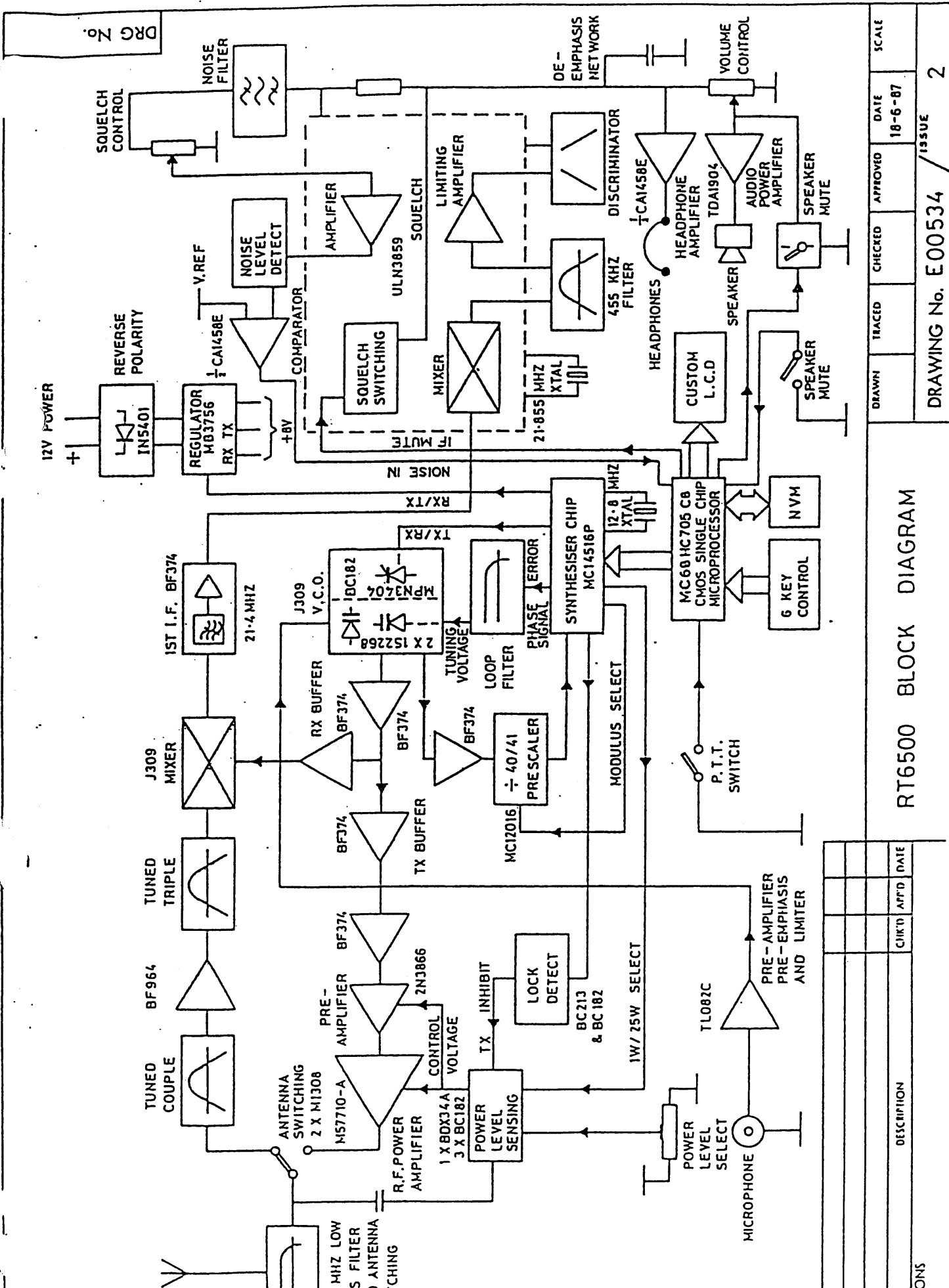

RT6500 BLOCK DIAGRAM

DRAWN	TRACED	CHECKED	APPROVED	DATE	SCALE
				18-6-87	

DRAWING No. E00534 / ISSUE 2

DESCRIPTION	CHK'D	APP'D	DATE

viii) Squelch:

The recovered audio signal from the demodulator will have high frequency components (up to 25 KHz) with the absence of an incoming signal. This noise is filtered by C27 and L11 and amplified by an amplifier built into IC1 (pins 12, 13). The level fed to the amplifier being controlled by the squelch potentiometer. The output of the amplifier (IC1 pin 13) is rectified and smoothed by D3, D4 and C24 and fed to comparator IC2a. The reference level is determined by R17 and R20 and hysteresis by R16.

The output of the comparator IC2 pin 1 is connected to the squelch circuitry in IC1 giving both a switch to ground (connected to the audio signal path) and a high logic level (connected back to the control PCB to give channel present signal).

4.3 Setup Procedure

For RT6500 setup please refer to drawing E00425 for the location of the test points

a) **Reference oscillator** - Measure frequency at TP "H". Adjust VC2 to give 12.8 MHz +/- 19Hz.

b) **VCO Tuning** - Measure voltage at TP "J", and adjust core L39 to give 7v (+0,-0.1), on highest frequency receive mode. Check at lowest frequency that this voltage is > 2.5v. Check that voltage is > 2.5v, and < 7v for lowest and highest frequency transmit respectively.

c) **Tuned circuit adjustment** - After major component replacement the tuned circuits on the RX/TX board will require resetting up. These tests require a spectrum analyser/tracking generator such as the Marconi 2955 to complete and hence the recommended course of action is to return the set to the factory for setup. Details of the setup procedure are available upon request from the factory for agents who have the necessary equipment.

4.4 BD6500 Circuit Description

The BD6500 handset is a full function bi-directional controller which interfaces to a special version of the RT6500. The BD6500 uses a serial communication system to instruct the radio to carry out its functions and determine the status of the channel in use. All the tone decoding and encoding is handled by the microprocessor in the RT6500BD radio. Filtering of the incoming signal and the transmitted tone is carried out by IC101 and its associated components. Drawing number E01656 shows the circuit configuration of the BD6500 handset.

IC1 is the microprocessor which controls all the functions of the BD6500. It reads the keypad matrix including the PTT switch and monitors the state of the cradle switch. The switch matrix is made up of 4 drive

lines R10 to R13 which strobe the switches. The key pressed is detected on the five inputs D5 to D9. The microprocessor has an integral LCD driver which drives an eight digit LCD using two phase multiplexing. The backplane is driven by pins COM1, and COM2 and the segments by SEG1 to SEG32. R20, R21 and R27 set the multiplex voltage levels for the LCD driver.

The oscillator for the micro IC1 use a 1.2MHz ceramic resonator. Note that the PCB layout has provision for a conventional crystal as well as a SXA style surface mount crystal. The resonator is fitted in the (XT) position. TR7 and TR8 form the power on reset control.

TR7 detects that the 5 volt rail has fallen below the reference set by zener diode D1 to generate a reset signal. Hysteresis is provided by the inverting action of TR8 through R6.

The pulse width modulated output R31 drives TR10 to control the lighting of the LCD. C13 slows the rising and falling edges of the drive signal to minimise noise. (Note that the 75R resistor R22 may be made up of two 150R resistors to ensure adequate power dissipation.)

Serial communication to the radio takes place on the cradle switch line and on the PTT line. All communications uses standard synchronous ASCII format using one start bit and one stop bit at 4800baud.

Data from the BD6500 to the RT6500BD is sent down the cradle line, which also echoes the state of the cradle switch. Care is taken to ensure that at the start of data transmission the line is placed at the correct level. Also the RT6500BD ignores the data when monitoring the state of the cradle switch. TR4 is used to buffer the data out. The BD6500 transmits instructions to the radio to control channel changing, power, illumination and entering the various search modes. It also sends instructions during transmit to send the appropriate tones used to make a call.

Incoming data is carried by the PTT line to IC1 pins D0, R32, and buffered by TR9 before being presented R01. This line is also used to detect that the radio has been turned off. The RT6500 is continuously transmitting data on the status of the received channel, and during the call setup phase it sends the tone or calling number being produced by the coast station.

Power to the electret microphone is supplied direct from the microprocessor pin D2, any noise being filtered by R17 and C8. The microphone is turned off both in receive and when signals are being exchanged with the coast station. The handset speaker is also muted by TR14 during the setup phases of the call. This is driven from IC1 pin R30 through TR15. This additional transistor is needed to provide the correct drive condition to TR14 because the collector may be driven negative in some circumstances.

5 Configuration and Programming

This section of the manual describes the setup of channel frequencies for the scanning versions of the RT6500, and the ID number for SELLCAL versions. Please read this section in full before attempting to alter the programming or configuration.

5.1 Private Channel Programming for the RT6500S.

This document describes the programming of channel frequencies for the RT6500S and the extended procedure used for the RT6500B.

There are two modes of programming the RT6500B:-

Mode A. to enter private channels which is identical to the procedure for the RT6500S as described in sections 5.4.1 - 5.4.5.

Mode B. extended procedure to enable the addition of normal International channels as described in section 6.

5.4.1 Entering Programming Mode.

Remove the front panel by loosening the four screws holding the main casing together. Several link pads will be found on the front panel circuit board. The accompanying drawing (E01311) shows their position. Identify the pad marked "3" (Pad 3) and short it out as shown on the accompanying drawing. Ensure that the existing link has been removed.

When the radio is turned on the display will show:-

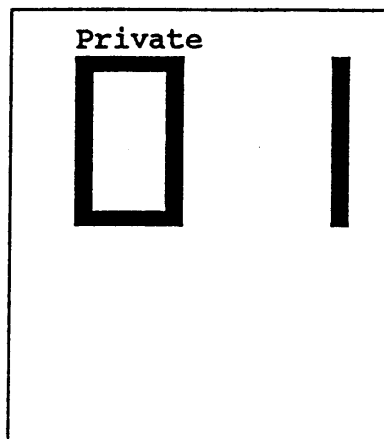

The legend "Private" will be flashing.

5.4.2. Selecting Channel Number.

The display is now showing the first free private channel number. If another private channel number is required this may be selected using the UP or DOWN keys. Once the private channel is chosen press SHIFT then ENTER to allow the frequency to be entered.

5.4.3. Entering a Frequency.

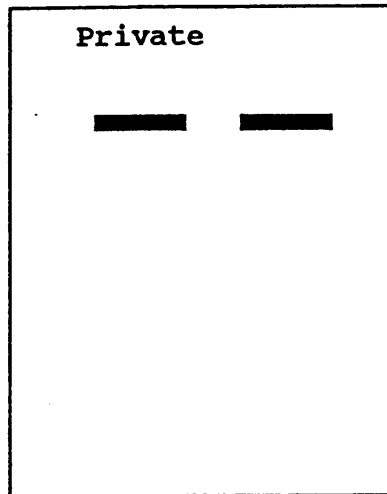

The legend "Private" will be flashing.

The lower frequency of the Rx/Tx pair may now be entered into the radio, i.e. the transmit frequency for duplex or simplex, the receive frequency for reverse duplex. Pressing the UP or DOWN keys will display either "15" or "16", for 150MHz or 160MHz. Use SHIFT then ENTER to select. The display will now scroll to display "50" or "60". The UP or DOWN keys are now used to select the units of megahertz. Pressing SHIFT then ENTER will select this frequency and scroll the display to the next digit.

Continue this process until all the digits of the frequency are entered. Note that the last two digits are only selectable in steps of 25kHz.

If the channel had already been programmed the display will show the existing frequency which may be altered as described previously.

NOTE: The radio is capable of being programmed from 150.000MHz to 169.975MHz. However Navico will only guarantee correct operation of the radio in the range 155.500MHz to 163.000MHz.

5.4.4. Selecting the Mode of Operation

simplex channels by the UP/DOWN keys. The mode may be changed to Duplex (ship mode) or Reverse duplex (shore mode). The display will either be:-

S or d or R

Pressing SHIFT then ENTER will enter the private channel into the non volatile memory (NVM), and the next private channel number will be displayed. Another frequency can now be entered by repeating steps 2 to 4.

5.4.5. Terminating the Programming Mode.

Once all the required channels are entered then the radio may be turned off, and the link returned to the original position. After the radio is reassembled check the operation of the radio, preferably using a suitable Radio Test Set.

5.5.6. Extended Programming Mode B.

If the unit is configured as a base station then the standard international channels may also be set up in the extended programming mode.

Pressing the "CH16" button whilst a private channel number is being displayed will cause the radio to enter this new mode.

(N.B. Private channels should be programmed in first as there is no way back into the first mode without turning the radio off and back on again.)

Any channel may be selected in the ordinary way using the UP/DOWN keys. The display will only show the channel number. When the SHIFT key is pressed the channel will be enabled for receive and transmit on one or twenty five Watts. This will be indicated by the four legends "Rx", "Tx", "1W" and "25W" being displayed. If the ENTER key had been pressed then the channel will be enabled for receive only, indicated by the lack of the "Tx" legend in the display.

Both of these functions are a toggle action so once a channel has been enabled it may be disabled.

Additionally the 1W/25W key may be used to select the channel for 1W only operation. In this case the "25W" legend will be blanked.

Any number of channels may be selected depending on the customer requirements. One channel may also be programmed as the start up channel by pressing the "CH16" key when that channel is being displayed.

The information is only stored into NVM when moving on to the next channel. Turning the radio off is the correct way to terminate programming operations. Do not forget to remove the solder short to the normal position on PAD 3 as described in section 5.4.5.

Private Channel Enable Position (pad3).

```

■
■ )
■ ) - LINK FOR NORMAL OPERATION
3

```

```

■ ) - LINK TO ENABLE PROGRAMMING MODE
■ )
■
3

```

5.5 ENTERING THE CALLING NUMBER

Test pads PD1 are used to enter the calling number of the handset. With the unit turned on short the two pads together momentarily. The display should show "id-----". Press the "#" key to erase any existing digits. The new number may be entered using the keypad. To "lock" the number into the unit short the PD1 pads briefly before turning the radio off.

1) TEST MODE

To initiate the test sequence of the handset the BD6500 is turned on and within one second the buttons 3, 4, 1, 2, 5, are pressed. The display will show "--tEST--". The following functions can be tested:-

1. Numeric keys are echoed in the display and produce the corresponding tone on the transmitter.
2. "#" will blank the LCD
3. "*" will turn all segments on
4. "F" will turn the lights on and display "Lights" on the display. Press "F" again to turn off.
5. "A" will display "Auto" on the display
6. "16" will display "161616" on the display
7. "S" will show "mute on" on the display. Pressing "S" again will show "mute off".
8. "M" will display "Mic on" and power the electret microphone up. Pressing "M" again will display "Mic off".
9. "C" will test the non volatile memory and display "9346" if it is correct or "ErrErr" if not.
10. The cradle switch will display "cradle" when the handset is on the cradle.
11. "PTT" will show "PttPtt" on the display when pressed.

6 Circuit/Mechanical Assembly Drawings.

The following is a list, description and issue number of the drawings in this section of the manual at the time of printing. This page is an index to the following sections that will be divided by a single page containing the section number.

6.1 PCB Circuit diagrams

- | | |
|-------------|--|
| Control PCB | 1) E00420 - Version 1 conventional mount control board - Issue 2 |
| | 2) E01309 - Early surface mount front panel - Issue 1 |
| | 3) E01169 - Version 2 surface mount control board - Issue 3 |
| | 4) |
| | 5) |
| RX/TX Board | 1) E00425 - RX/TX PCB - Issue 11 |
| | 2) |
| BD Handset | 1) E01656 - BD Handset PCB - Issue 2 |
| | 2) |

6.2 Parts Lists and Circuit Layout

- 1) E01310 - Front panel assembly and parts list - Issue 4.
- 2)
- 1) E01311 - Front panel PCB assembly and Parts list - Issue 2.
- 2)
- 1) E00422 - Component Layout RX/TX board - Issue 4.
- 2)
- 1) - Rx/TX parts list.

6.3 Mechanical Assembly Drawings

- 1) E01425 - RT6500 main assembly - Issue 2
- 2) E01937 - RT6500 main assembly - Issue 1
- 3)
- 1) E00446 - Fistmike assembly - Issue 3
- 2)
- 1) E00459 - Handset assembly - Issue 2
- 2) E01796 - Ver B Handset - issue 1
- 3)
- 1) E01748 - BD handset assembly - Issue 1
- 2)

Please add new issues by hand in the spaces provided.

6.2 RT6500/RT65008 Components List (Valid from S/No. IC26724)

The component layout and the parts list for the front panel assembly is shown in drawings E01311 (Iss 1), which is a sub assembly of drawing E01310 (Iss 4), the final assembly drawing.

The component layout for the RX/TX board is shown in drawing E00422 issue 4, and the parts list is given below.

RT6500 RX/TX Circuit diagram E00425. PCB assembly E01831

Circuit Reference	Part NO	Description	Manufacturer
Semiconductor Devices			
TR1	130025	BF964 Dual Gate Mosfet	A.E.G.
TR2,14	130008	J309 J Fet	Motorola/Siliconix
TR5,6,11,12,13	130022	BF374	Motorola
TR4	130023	2N3866	Motorola/TRW
TR7,8,9,16,17,	130000	BC182 (or equivalent)18,19,20,21	
TR10A	130002	BC327PNP	RCA
TR15	130005	w213 (or equivalent)	
D1	120025	MI308 Pin diode	Mitsubishi
D2	120034	MI407	
D3,4,9,11,15,16,	120000	1N414817, 18, 19	
D5, D6	120003	BAT85 Schottky diode	Mullard
D7	120002	1N5819	Motorola
D8	120001	1N5401	
D10	120006	6V8 Zener diode 400mW	
D21	120008	5V1 zener diode 400mW	
D12,20	120016	1S2268 Varicap	Hitachi
D14	120016	2x IS2268 Varicap	
D13	120026	MPN3404 pin diode	Motorola
D24	120046	3V3 Zener Diode 400mW	
IC1	140037	ULN3859/MC3359P IF chip	Sprague/Motorola
IC2	140000	CA358E Dual op amp	
IC7	140048	TDA1904 2w audio amp	S.G.S.
IC4	140039	MC145156P Synthesiser	Motorola
IC5	140044	MC12016P Dual Modulus Prescaler	Motorola
IC6	140046	CA082E Dual op amp	
REG1	140029	MB3756 Triple + 8v regulator	
R.F. Amplifier	140038	M57710/A 25 watt	Mitsubishi
SK1	170035	16 way D.I.L. socket	

NOT FITTED: TR3, D22, D23, TR10

DELETED: IC3.

Inductors/Chokes

L1, 12	E00539	5.5T 20 SWG	Navico
L13,14,15	E00538	3.5T SWG	Navico
L28,29	E00540	12.5T 0.7cu Wire	Navico
L17	E00537	3.5T 22 SWG	Navico
L18, 20	E00536	2.5T 22 SWG	Navico
L19	E00535	3.5T 22 SWG	Navico
L5,25,27,36, 37,41,42,43	240015	1H choke	
L40	240014	4.7H choke	
L24,33,38, 26	240017	10H choke	

L10,11	240016	1mH choke	
L2,3,4,6,7,23,30	240006	166XNA-11078Y	Toko
L8,9	240007	TKXC-27894N	Toko
L21,22	240005	166XNA-11069X	Toko
L39	240021	E526HN-100102	Toko
L31	240010	RMC-15002A	Toko
L34,35	240018	3-3 6 amp choke	
X1	160010	12.8MHz xtal 5 ppm	
		(-15 to +60 C)	
X2,3	160018	4 pole xtal filter 21.4MHz	
		(supplied as matched pair)	
X4	160006	21.855 MHz xtal 7.5 ppm	
		(-15 to + 60C)	
X5	160005	6 pole ceramic filter 455 Kz	Murata/Kyocera
TH1	100116	N.T.C. Thermistor R(25C) = 4k7	

NOT FITTED: L44

DELETED: L16, L32.

Capacitors

C8,78,93	110067	Op68 Tubular ceramic
C5, 13, 157	110066	1p2 Tubular ceramic
C14,57	110044	2p2 Ceramic disc NPO
C4,158,124	110086	3p3 Ceramic disc NPO
C1, 48, 160	110045	4p7 Ceramic disc NPO
C9, 19	110046	5p6 Ceramic disc NPO
C12, 80, 63, 106	110047	6p8 Ceramic disc NPO
C52, 121,164	110048	8p2 Ceramic disc NPO
C2,53,79,118,125	110049	10p Ceramic disc NPO
C126	110058	56p Ceramic disc NPO
C146	110050	12p Ceramic disc NPO
C55		14p2 Ceramic disc NPO
		(12p//2p2)
C94	110051	15p Ceramic disc NPOC54
		24p Ceramic disc NPO
		(2 x 12pF in parallel)
C64,74	110053	27p Ceramic disc NPO
C58		27pF Ceramic disc NPO
		(12p//15p)
C72	110056	47pF Ceramic disc NPO
C66	110090	82pF Ceramic disc NPO
C42,47,105	110088	100pF Ceramic disc NPO
C130	110062	390pF Ceramic disc Z5U
C6,7,10,11,15,	110065	1nF Ceramic disc Z5U
18,32,41,51,59,		
16,62,67,68,70,71,75,		
76,81,82,85,86,87,		
88,89,91,92,95,		
96,98,99,100,104,111		
112,114,115,116,117,		
119,123,133,145,142,		
122,150,155,159,170,171,		
172,175,177,178,179,180,		
186,187a,188, 195,196.		
C27	110079	1nF Polyester box 10%
C28	110080	6n8 Polyester box 10%
C21,113,	110000	10nF Ceramic disc Z5U
183,184, 69.		
C131,140,154	110081	10nF Polyester box 10%
C135	110082	15nF Polyester box 10%
C136	110083	22nF Polyester box 10%
C128	110084	47nF Polyester box 10%
C44,45,90,139,	110001	100nF Ceramic disc Z5U

148, 161, 174, 187b, 173, 193		100nF Polyester box 10%
C40, 23, 29	110078	0.22 F 25V Electrolytic
C24, C132, C169	110026	1 F 63V Electrolytic
C141	110069	2 2 16V Electrolytic
C134	110097	2 2 16V Tantalum 20%
C138	110085	4 7 16V Electrolytic
C25, 30, 31, 35, 39,	110003	
137, 152, 156, 129,		
166, 167		
C120, 163	110017	4 7 16V Tantalum
C50, 65, 97, 110, 73,	110028	22 F 16V Electrolytic
168		
C60, 61	110089	22 F 25V Electrolytic - low profile
C103, 165	110030	47 F 16V Electrolytic
C101	110004	100 F 16V Electrolytic
C34, 38	110087	220 F 25V Electrolytic
C46	110007	1000 F 25V Electrolytic
VC2, 3	110092	1-10pF Ceramic variable

NOT FITTED:

C3, C127, C149, C151, C153, C162, C176,
C181, C182, C185, C189, C190, C191, C192,
C194, .VC1.

DELETED:

C26, C33, C36, C37, C49, C56, C77, C83, C84,
C102, C107, C108, C109, C143, C144, C147.

Resistors

All resistors - carbon film 5%		
R115	100008	4R7
R32, 35	100009	5R6
R31	100012	10R
R38	100018	33R
R60, 103	100020	47R
R10, 102, 105, 116	100105	51R
R3, 4, 5, 34, 37, 55,	100024	100R
113,		
R41, 53, 62, 61	100028	220R
R125	100030	330R
R42	100031	390R
R39, 48, 78, 79,	100032	470R
66, 112, 121		
R7	100033	560R
R50	100034	680R
R9, 18, 22, 58,	100036	1K
81, 111		
R47, 76	100037	1K2
R8, 11, 33	100038	1K5
R36, 46, 94, 101	100040	2K2
R20	100041	2K7
R74	100042	3K3
R44, 49, 89, 90	100044	4K7
R68, 110	100045	5K6
R15, 108	100046	6K8
R63	100047	8K2
R43, 51, 65, 69, 73	100048	10K
77, 83, 84, 85, 93,		
104, 106, 57, 109		
R70, 71, 72	100102	11K
R25	100049	12K
R30, 21, 114	100050	15K
R17, 56, 86, 87,	100052	22K

Navico Service Manual

Draft 3.0

88,100				
R59	100053	27K		
R16,27,75	100054	33K		
R2,28,40,52, 54,82	100055	39K		
R92,95	100056	47K		
R26	100058	68K		
R1,19,23,29,91	100060	100K		
R80,99	100069	560KV		
R1,3	150023	10K	Cermet Preset	Bourns
VR2	150022	500R	Cermet Preset	Bourns
VR4	150025	200R	Cermet Preset	Bourns

NOT FITTED: R12,R13,R98,R117,R118,R119,R120,R122.

DELETED: R6,R14,R24,R45,R64,R67,R96,R97,R107

6.4 Minimum Spares Stockholding

Item	Part No	Description	Quantity
1	140038	M57710-A 25W R.F. module	1
2	270003	Fuse 7.5 A	10
3	E01334	PCB Assembly RX/TX Board Ver 2	1
4	E01636	PCB Assembly RT6500 Front Panel Ver 2	1
5	FTM2	Fist mike for the RT6500	1
6	THS2	Telephone handset for the RT6500	1
7		IM407 Pin Diode	5
8		8 Ohm loudspeaker	1
9		Assortment of resistors and Capacitors	

7 Product Variations**7.1 Historical List of Modifications.****7.1.1. Tuning Components in the VCO**

a) Very early boards (serial numbers prior to DE250 and supplied in the U.K.) had the following values:

R61 = 47R
 C121 = 6p8
 C124 = 4p7
 C126 = 6p8
 C127 = 1p2
 C149 = 22p
 C149 = 22p
 C151 = 5p6
 C129 = 0.1 μ

These values should all be changed to the following (b) if a unit is sent in for repair.

b) On all boards up to DG1600, the following values were fitted:

R61 = 470R
 C121 = 8p2
 C124 = 3p3
 C126 = 8p2
 C127 not fitted
 C149 = 15pF
 C151 not fitted
 C153 = 3p3 fitted on test if necessary
 C129 = 4 μ 7

c) On all boards from DG1600 onwards, the following changes were made:

C126 = 10pF
 C149 = 22pF
 C153 = 3p3 fitted on test

7.1.2. Power Control

On all boards from DG1600 onwards and on the following sets :

* DE559-583 supplied to Denmark
 Implemented by modification on pcb
 DF680-729 supplied to Norway ditto
 DF826-860 supplied to Denmark ditto
 DF971 ditto
 DF1036-1085 supplied to Norway
 Using new pcb including the preset referred to
 DG1186-1235 supplied to Norway in item 4
 DG1265-1314 supplied to Norway ditto
 DG1315-1364 supplied to Denmark ditto

A buffer stage was added to the 1W-25W control line changing the sense of the signal on pin 15.

The following changes were made:-

- a) TR21 and R109 added
- b) REG1 pins 6 and 8 function reversed
- c) Software on UK sets updated from A1 (B1) to A2 (B2) on later versions.

All other software already contained this modification.

7.1.3. RX-TX Switching

All boards should have a 4.7µF tantalum capacitor (now numbered C163) added in parallel with C161.

7.1.4. Squelch

On RT6500 units before DG1600 the squelch sensitivity was adjusted with a resistor of between 68R and 150R added to the front panel pcb assembly.

From DG1600 onwards, VR4 is fitted to the Rx-Tx pcb to adjust the squelch setting.

7.1.5. IF Amplifier

On all units from ED6105 onwards the first IF amplifier has been removed.

Components removed are

TR3
R12
R13
R107

C22 is connected directly to pin 18 IC1.

7.1.6. On units with boards dated 1988 and used on:

Sets supplied to Germany, Serial Numbers

EC4803 - EC4852
EC5025 - EC5045
EC5056 - EC5154
EC5157 - EC5210
EC5259 - EC5261
EC5263 - EC5319
EC5383 - EC5528
EC5533 - EC5589
ED5507 - ED5620
ED5713 - ED5722
ED6263 - ED6291
ED6294 - ED6305
EE6342 - EE6470
EE6474 - EE6556
EE6672 - EE6676

On all units from Serial number:
the following changes were made:

a) Audio Amplifier: this has changed to a TDA1904, the associated circuitry has also changed

b) Temperature compensation: the following components were added, to provide compensation of the 12.8MHz reference crystal:

R110
R111
R112
D20
D21
TH1

The value of C106 is changed from 22pF to 4p7.

c) Power control take off: C57 is now connected to the junction of D2 x L15.

d) Modulation frequency response: the value of C134 has been reduced to 2.2 microfarad.

e) VCO: the following value has been changed: ~~C149~~
= 27pF

f) Front Panel PCB's: the circuitry associated with TR2 controlling the reset and standby modes has been redesigned. An input to the micro from the mute line has been added via R38, and decoupling added to the LCD drive lines. These modifications are detailed on drawing D00420 revision 1.

7.1.7 Squelch

From FD10993 onwards the following modification was made to improve the range and hysteresis of the squelch circuit.

IC2 changed from CA1458E to CA358E
R17 changed from 6k8 to 22k
R16 changed from 12k to 33k
R121 added to rear of PCB value 470R.

7.1.8 Increased Frequency Range TX

From Serial Number FL15052 onwards the following changes were made to extend the transmit range to 163MHz.

a) VCO L3 changed from 27629 to 35-00714
 C125 changed from 12pF to 10pF
 C126 changed from 10pF to 56pF
 C149 not fitted
 C164 now 8p2
 D14 now 2 x IS2268 in parallel
 R118 (330R) & L43 (1H) have been added from

TR14 source to TR14 gate.

b) Output Filter

C160 changed from 3p3 to 4p7

C158 changed from 2p2 to 3p3

C53 changed from 12p to 10p

7.1.9. Line Borne Audio Interference

From Serial Number FL15052 onwards the following changes were made to the audio amplifier to reduce conducted noise into the radio from fridges, motors, etc.

C33 removed

C174(100n) added from IC7 pin 3 to OV.

Also, OV sig pin of SKT1 is connected to OV locally to IC7. This is pin 13 for use with conventional front panel PCBs and pin 14 for use with surface mount front panel PCBs.

7.1.10. Surface Mount Technology Front Panel PCB.

From Serial Number GD17600 (and Serial Nos. GC1687 - GC16930 inclusive) a re-designed front panel was introduced. See Drawing No. E01169. This required the following changes to be made to the main PCB.

R14 removed

IC2a pin 1 connected to SKT 1 pin 7.

IC1 pin 16 connected to SKT1 pin 16 (remove connection to IC1 pin 7)

This modification gives the microprocessor control over the squelch. Other features of the new design are easy configuration of the radio by select pads on the non-scanning versions and by NVM on the scanning versions. Private channels may be entered directly into the scanning versions by authorised dealers. Cloning and personal computer entry options are also possible. The function of pin 6 on the microphone socket is changed. It is now a 12V un-switched supply on which data may be sent.

7.1.11. Detailed Changes Pre-Version B.

The following changes were made to the RX/RTX board after the introduction of the surface mount front panel (drg E01309), prior to the introduction of the version B unit (new SM panel drg E01169).

a) 10K resistor added R4.

b) C106 changed from 6p8 to 8p2.

- c) Component specification change from U62 to U602.
- d) Squelch pot changed from logarithmic to linear.

7.1.12 Version B (From IC26724)

a) **Front Panel Assembly** - Remains essentially the same, but is finished with a textured appearance. This part is fully interchangeable with previous versions.

b) **Main Body assembly** - Part No. E01832.
This differs from previous versions as follows:

1. Both top and bottom case castings are alochrome treated to resist corrosion.
2. Both top and bottom case castings are finished in a durable texture paint.
3. The top casting has a strong rib between each heatsink fin. This prevents damage to the case when the unit is dropped or knocked.
4. No battery compartment cover is fitted. Holes through the casting where this was located have been filled.
5. Antenna, power and audio output connectors are fitted directly to the case bottom. The casting has been modified to accommodate this and gives 2 advantages.
 - (i) improved r.f. screening
 - (ii) moisture (condensation) cannot enter the case when the radio is mounted in an inverted position.
6. A new type power connector is fitted.
7. A revised PCB assembly is fitted to accommodate changes above.

c) **Power Cable** - A new type is supplied with different connector type (spare part identifier PWL6500VERB). This uses an extruded cable pair, which is neater and more flexible than previous versions. Chokes are not fitted as they are no longer required.

d) **Handset** - Version B radios have a new handset (THS 2) that is not compatible with non scanning version A radios without a modification to the Control PCB (E01169). The Diode D201 needs adding to the control board to feed power to the new handset on these models.

e) **Manual** - A revised Owners Manual is supplied.

f) **Packaging** - New packaging, using corrugated card, is used.

7.1 Historical List of Software Modifications.

The versions of the software described are pre-programmed into IC1 on the Front panel or control Board. (E01169)

1) Standard Versions of the RT6500 (part No E01308)

E01308-01 - Initial version using Motorola IC. Date of introduction March 1990.

E01308-02 - Extended test mode added, dual watch timing problem cured, SELCALL RX speeded up, and unused tones eliminated. Date of introduction April 1990.

E01308-03 - Assembly error corrected, squelch line is now being driven. May 1990

E01308-04 - Auto dialler assembly error corrected. Enhancements made to code - Internal memory enables/disables SELCALL number editing, speaker mute controlled by internal memory. July 1991

E01308-05 - Mask version of S/W. Changed attributes for Holland, channels 37 and M2 disabled in some modes, saving in memory implemented. August 1991

2) BD Versions of SW (Part Number - E01677)

E01677-0 Initial version for BD (July 1991)

E01677-1 Cure of assembly bugs (August 1991)

E01677-2 Changes made for compatibility with the French auto-dialler system.

3) Other versions

E01961-0 First Provisional version for the French West Indies dialling system.

E01961-1 Delay added to auto-dial for the French West Indies.

E01414-01 & 02 - Special sets to customer order.

4) BD Handset Software (E01774)

The SELCALL versions of the RT6500 have a second microprocessor and resident software housed in the

handset in IC1 (PCB Drawing Number E01656).

E01774-01 - Initial Production Version of the BD software.

E01774-02 - S/W added to aid factory setup, and entering of call numbers. Illumination improved, and "off the hook" dialling now allowed.

E01774-03 - Change of crystal resulted in S/W change.

E01774-04 - Timing of tone transmission changed.

8 Trouble Shooting Guide

a) A broken core in the fistmike or handset cable will cause mis-operation, and it a simple task to try a replacement unit. Check this especially on worn or heavily used sets.

b) Pin Diode D2 (IM407) can fail after extended use, and is easily replaced with the RX/TX board in-situ.

c) Dry or damaged solder joints on the microphone socket on the control PCB can be a cause of transmit failure. Check this connection especially if the Control board has been removed from the front panel for service or inspection.

d) On older radios check for damaged, worn, or dry solder joints (or wire cores) on the interconnecting ribbon cable between the RX/TX and the control PCB.

e) Switch failure of the on/off switch can be a problem in older units.

d) Incorrect re-assembly of the ribbon cable connection between the control PCB and the RX/TX PCB can cause the track to the on/off switch (Control PCB) to burn out.

9 Update Sheets

All bulletins and service updates relating to the RT6500 should be filed in this section of the manual.

<u>COMPONENT REF.</u>	<u>PART N°</u>	<u>DESCRIPTION</u>
PCB	E01311	PCB ASSY. : SURFACE MOUNT.
R22	100115	3R9 5% 1/2 watt
R10	100101	75R 5% 1/2 watt
LP1,LP2	220000	683 3mm dia 5V 60mA bulb
LCD	E00418	TR105 custom LCD
VR1	E01524	100kB 16mm switched pot
VR2	E01306	1kB 16mm pot
S1-6	210012	6mm push button switch
SKT1	170061	2pin 0.1" right angle plug
SKT2	E00441	16pin DIL ribbon cable assy
	E01387	Painted lighting block
Option C	180028	24swg link wire
IC3	140053	9346 EEPROM

WAS A 150020
WASA 150021

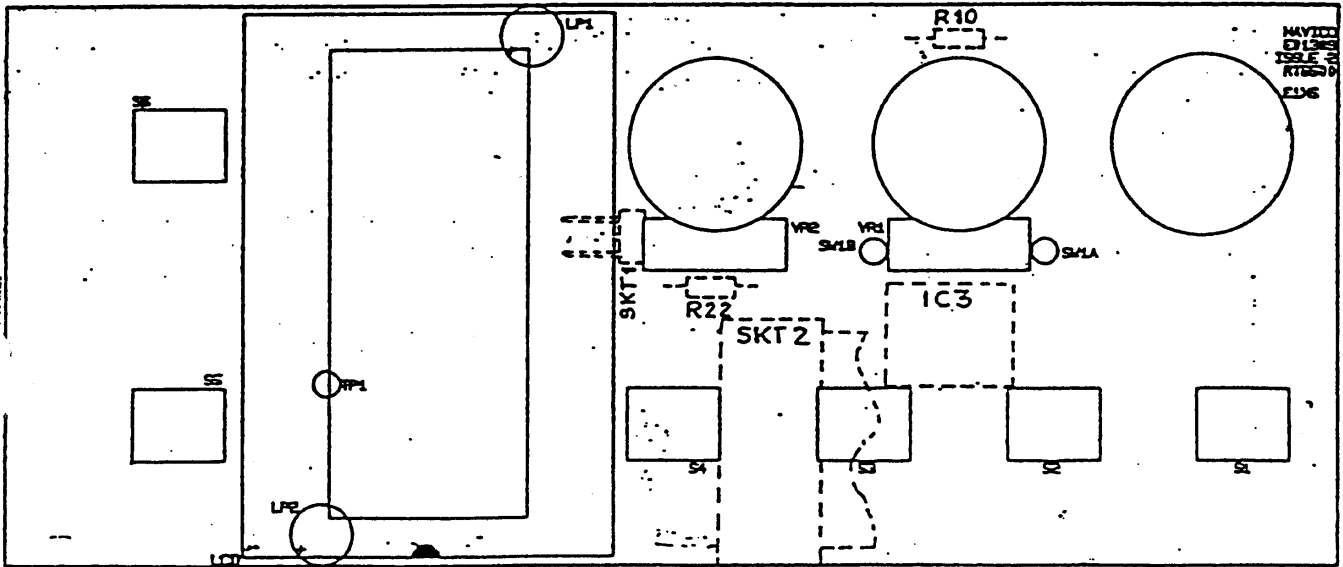

GENERAL DRAFT ANGLE IS / U.O.S.
GENERAL WALL THICKNESS IS / U.O.S.
ALL DIMENSIONS ARE IN METRIC / U.O.S.
DIMENSIONS MARKED * ARE TO BE ADJUSTED
U.O.S. = UNLESS OTHERWISE STATED
THIS DRAWING SUPERSEDES ALL OTHER ISSUES

DO NOT SCALE		IF IN DOUBT ASK		No	3	ISS	11-9-90	DATE	E01524 WAS E01305	MODIFICATIONS	
DRAWN BY B.M.		MATERIAL -		MODEL RT6500		LIMITS MET + Δ - 0. = .50 0.0 = .25 .00 = .10 ANG = 0.5		LIMITS IMP + Δ - FRAC = .015 .00 = .010 .000 = .005 ANG = 0.5		APPROVED AW	
DATE 21-2-92		DATE: 12-03-90		SCALE: -		TITLE PCB. ASSY. F/PANEL : VER. 2		DRG No E01310		ISSUE 4	

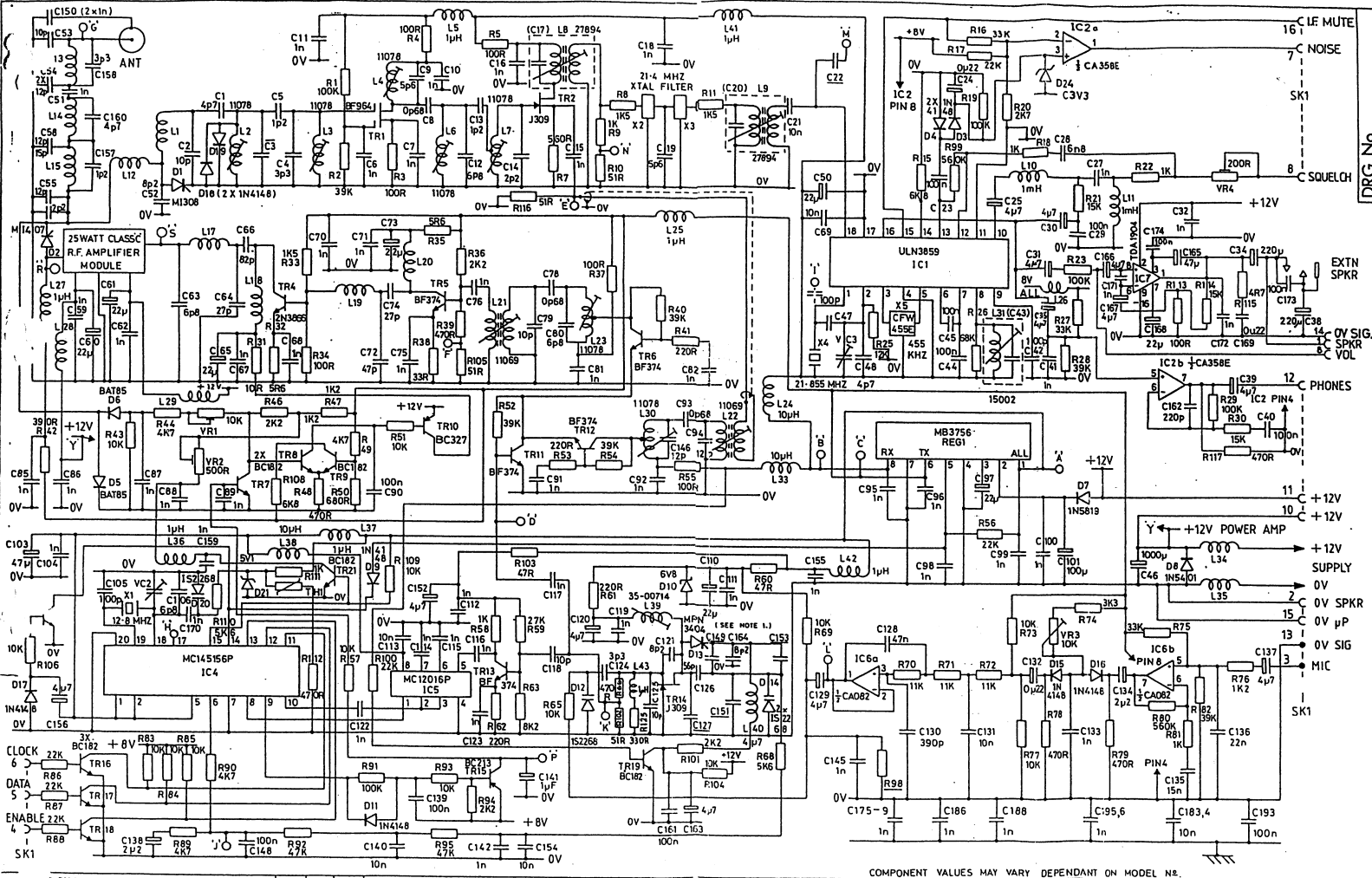

0	D70, R1, R10 - 112, 111		11-11-88	
1	REMOVED C24, ADDED C163, 164, C150 X 3, R104 TO 12V, ADDED C161, 162		17-11-87	
			4-7-87	
No.	DESCRIPTION	CHK'D	APP'D	DATE
2				
3				
4	ADDED 2, 3 TEST PADS, REMOVED L43, 1125 WAS 1118			7-10-91
11	C15 - 9, C123, C186, C188, C193, C195, 6, ADDED			10-11-91

RT6500 RX/TX P.C.B. CIRCUIT DIAGM

© NAVICO 1987 (0843) 290290

C13 WAS 0p68.

COMPONENT VALUES MAY VARY DEPENDANT ON MODEL NO.				14-3-86	DRAWN	TRACED	CHECKED	APPROVED	DATE	SCALE
6	ADDED C170-172			17-2-88	R.D.F.					
5	C32 NOW NON ELECTROLYTIC			20-1-88						
4A	ADDED C165 - 169, IC2, R113 - 115.			20-1-88						
4	REMOVED C26, 27, IC3, R24.			20-1-88						
No	DESCRIPTION			DATE						
7	REMOVED R13, 107, 113.			26-5-91						
8	D18 WAS 15158# R7 WAS 51R, ADDED R15, R31, 110W, J1, R52, 110W, 152, IC4, 110W, MC13016P			7-11-91						

DRAWING No. E00425 ISSUE 11

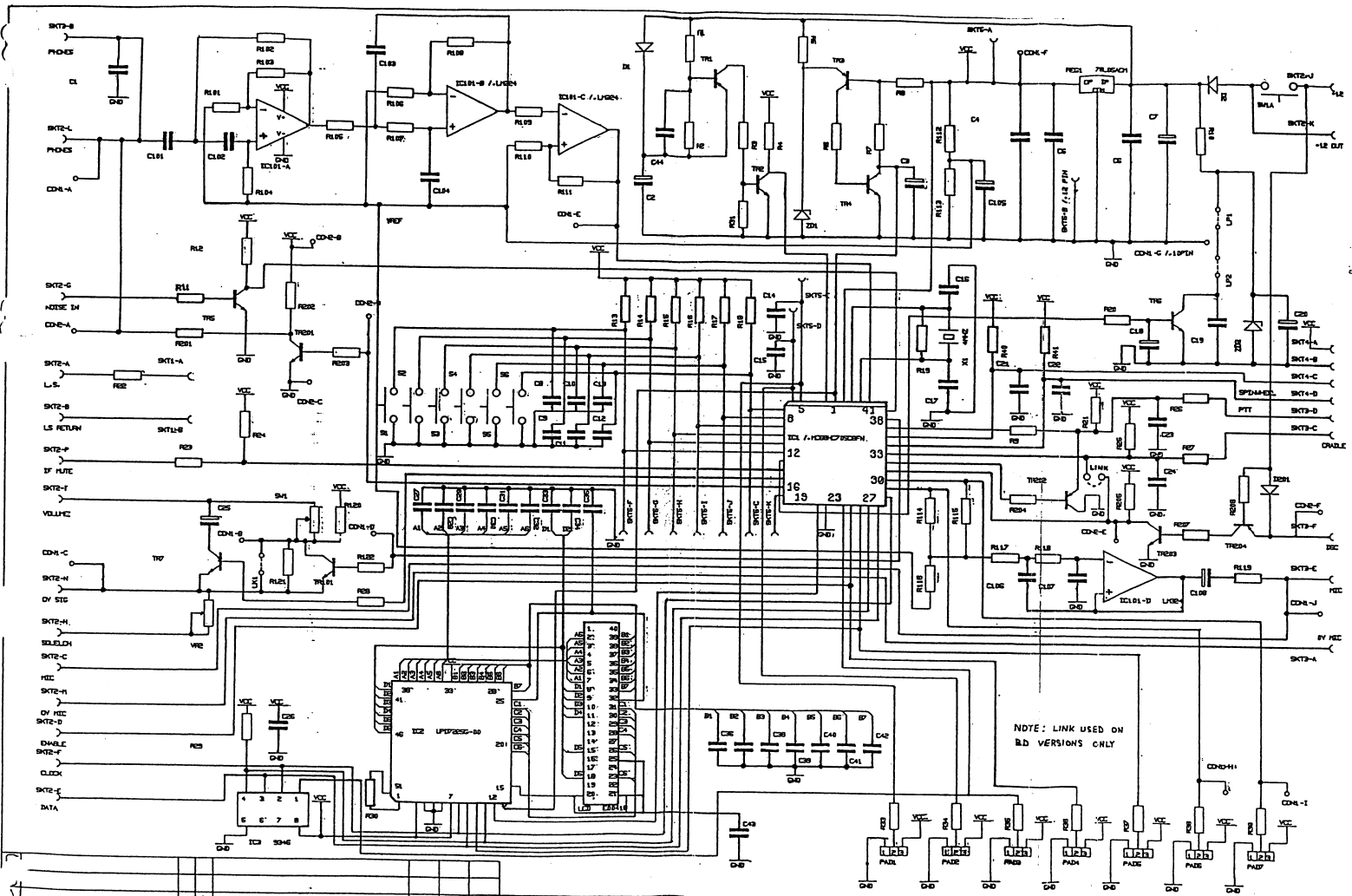

NOTE: LINK USED ON
RD VERSIONS ONLY

NO	DESCRIPTION	CHKD	APPD	DATE
	1 RD VERSION LINK ADDED			22-7-91
	©NAVICO LTD. 90.			

CIRCUIT DIAGRAM: RT 6500 FRONT PANEL
RT6500 VERSION 2

DRWN R. BENTFIELD AutoRoute Ltd	TRACED —	D-EDDED D.C.S 22-7-92	APPROVED AD 22-7-91	DATE	SCALE
DRAWING NO. E01169			ISSUE	3	

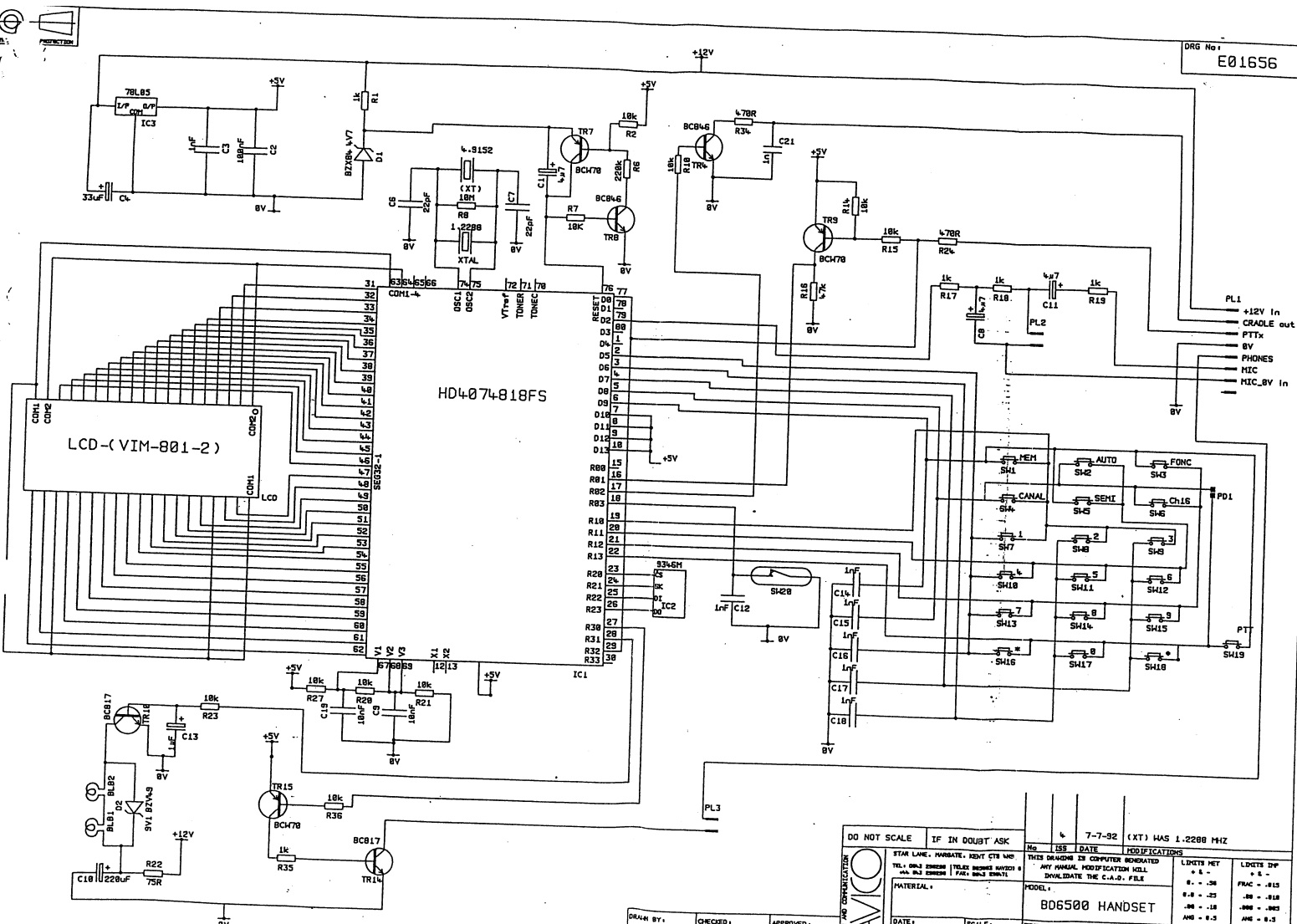

DRAWN BY: A.B.
 CHECKED: *AW*
 DATE: 22/11/90
 APPROVED: *MS*
 DATE: 10/3/92

DO NOT SCALE	IF IN DOUBT ASK	7-7-92 (XT) HAS 1.2288 MHz
STAR LINE, INHABIT, KENT CTB AND	THIS DRAWING IS COMPUTER GENERATED	INDICATORS
TEL. ORAL ORDER (TELE. ORDER SERVICE)	ANY MANUAL MODIFICATION WILL	LINETS NET
MAIL ORDER (MAIL ORDER SERVICE)	INVALIDATE THE C.A.D. FILE	LINETS DTP
MATERIAL:	MODEL:	0 - .36
	B06500 HANDSET	0.0 - .25
		.00 - .18
		.000 - .003
		.000 - 0.3
DATE: 22/11/90	SCALE:	TITLE:
		CCT DIAG : B06500
		ORG No: E01656
		ISSUE: 4

COMPONENT REF.	PART N°	DESCRIPTION
Option D		
R204	100131	4k 5%
R205,206	100132	10k 5%
R207	100135	47k 5%
TR203	130028	BC846B SOT-23 s.m. transistor
TR202,204	100029	BCW70 SOT-23
Option E		
R116,121	100128	1k 5% 1206 surface mount resistor
R105,107,112, 100143		6k8 5% 1206 surface mount resistor
113		
R109,110,120, 100132		10k 5% 1206 surface mount resistor
122		
R102,104	100144	15k 5% 1206 surface mount resistor
R106	100134	33k 5% 1206 surface mount resistor
R101,103,108	100135	47k 5% 1206 surface mount resistor
R111	100138	330k 5% 1206 surface mount resistor
C105	110104	4u7 16V AL-MF s. m. electrolytic
TR101	130028	BC846B SDT-23 s. m. transistor NPN
IC101	140071	LM324 SO-8 surface mount quad opamp
Option F		
R117,118	100143	6k8 5%
R114,115	100132	10k 5%
R119	100135	47k 5%
C108	110104	4u7 16v AL-MF s.m. electrolytic
Option G		
R41,42	100135	47k 5%
C21,C22	110107	1n 1206 surface mount ceramic
Option H		
C27-C43	110107	1n 1206 surface mount ceramic
Option I		
R201,202	100128	1k 5% 1206 surface mount resistor
R203	100135	47k 5%
TR201	130028	BC846B SOT-23 s.m. transistor

COMPONENT REF.	PART N°	DESCRIPTION
PCB		
Option A		
R9,26,27	100124	470R 5% 1206 surface mount resistor
R5	100128	1K 5%
R28	100131	4K7 5%
R4,6,8,12,20, 100132		10K 5%
23.		
R11,13-18,21, 100135		47K 5%
24,25,29,35,37		
R7	100137	220K 5%
R30	100138	330K 5%
R19	100139	10M 10%
C16	110111	12p 1206 surface mount ceramic NPO
C1,5,6,8-15, 19,23,24,26	110107	1n 1206 surface mount ceramic
C4	110105	100n 1206 surface mount ceramic
C3,18	110103	1uF 16v AL-MF s.m. electrolytic
C25	110104	4u7 16v
C7,20	110102	33uF 25V AL-MV s.m. electrolytic
D2, 201	120040	LL4001G MELF surface mount diode
ZD1	120037	BZX84-4v7 SOT-23 surface mount zener
ZD2	120039	BZV49-9v1 SOT-23 surface mount zener
TR3	130029	BCW70 SOT-23 s.m. transistor PNP
TR4,5,7	130028	BC846B SOT-23 s.m. transistor NPN
TR6	130030	BC817-25 SOT-23 s.m. transistor NPN
REG1	140067	78L05ACM SQB s.m. regulator 5V
IC1	E01308	MC68HC705C8FN Programmed micro
IC2	140042	uPD7225G-00 lcd driver
X1	160029	4MHz SXA s.m. crystal
C17	110108	22p 1206 surface mount ceramic
R22	100115	3R9 5% 1/2 watt
R10	100101	75R 5% 1/2 watt
LP1,LP2	220000	683 3mm dia 5V 60mA bulb
LCD	E00418	TR105 custom LCD
VR1	E01305	100k 16mm switched pot
VR2	E01306	1k 16mm pot
S1-6	210012	6mm push button switch
SKT1	170061	2pin 0.1" right angle plug
SKT2	E00441	16pin DIL ribbon cable assy

COMPONENT REF.	PART N°	DESCRIPTION
Option B		
R33,34,38,39	1100135	47k 5% 1206 surface mount resistor
R36	1100132	10K 5%
Option C		
IC3	140053	9346 EEPROM

NB REFER TO RED PRIOR TO MANUFACTURE OF VERSION 6 RE E01308 (MICRO) REMOTE

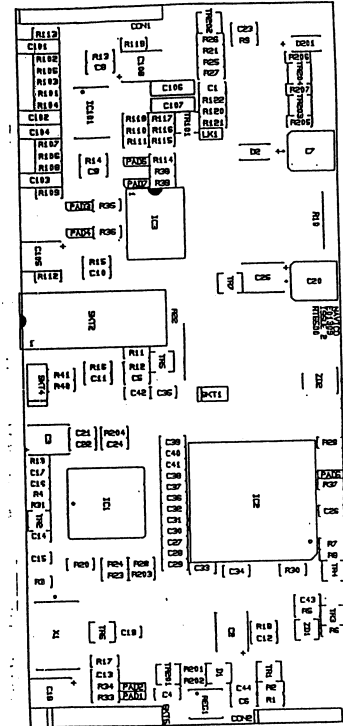

FOR CONVENTIONAL MOUNT COMPONENTS - SEE DRG. N° E01310

DO NOT SCALE IF IN DOUBT ASK		1	2	15-7-92	C17 WAS 110111 CHANGE NOTE 341 IMPLEMENTED
NAVICO		STAR LANE, MARGATE, KENT CT9 4NP		LIMITS MET	
TEL: 0843 290290		TELEX 965093 NAVICO G		LIMITS	
FAX 0843 290471		MATERIAL		+ & -	
DATE: 30-05-90		SCALE: -		FRAC =	
TITLE PCB ASSY.		MODEL RT6500		0.0 = .25 .00 =	
F/PANEL: S MOUNT		DRG No E01311		.00 = .10 .000 =	
				ANG = 0.51 ARG =	

THIS DRAWING SUPERSEDES ALL OTHER ISSUES

DRAWN BY DCS / BM	CHECKED DCS	APPROVED AG
DATE 15-7-92	DATE 15-7-92	

THIS DRAWING APPLIES FROM
SERIAL NUMBER 1C26724
(EXCEPT FOR SOME RT6500BD UNITS)

MODEL No.	COMPLETE FRONT PANEL ASSY.	P.C.B. ASSY.	FRONT PANEL + WINDOW
RT6500	E01313	E01310	E00444
RT6500B	E01640	E01636	E01376
RT6500BD	E01783	E01676	E01655
RT6500S	E01638	E01636	E00445
RT6500SC	E01639	E01637	E01587
RT6500BD (WII)	E01979	E01977	E01978

VIEW OF REAR OF CONNECTOR

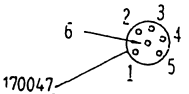

PIN FUNCTION

- 1 - O.V.
- 2 - PHONES (300 OHM)
- 3 - SPKR MUTE
- 4 - P.T.T.
- 5 - MIC (300 OHM)
- 6 - DATA / 12V

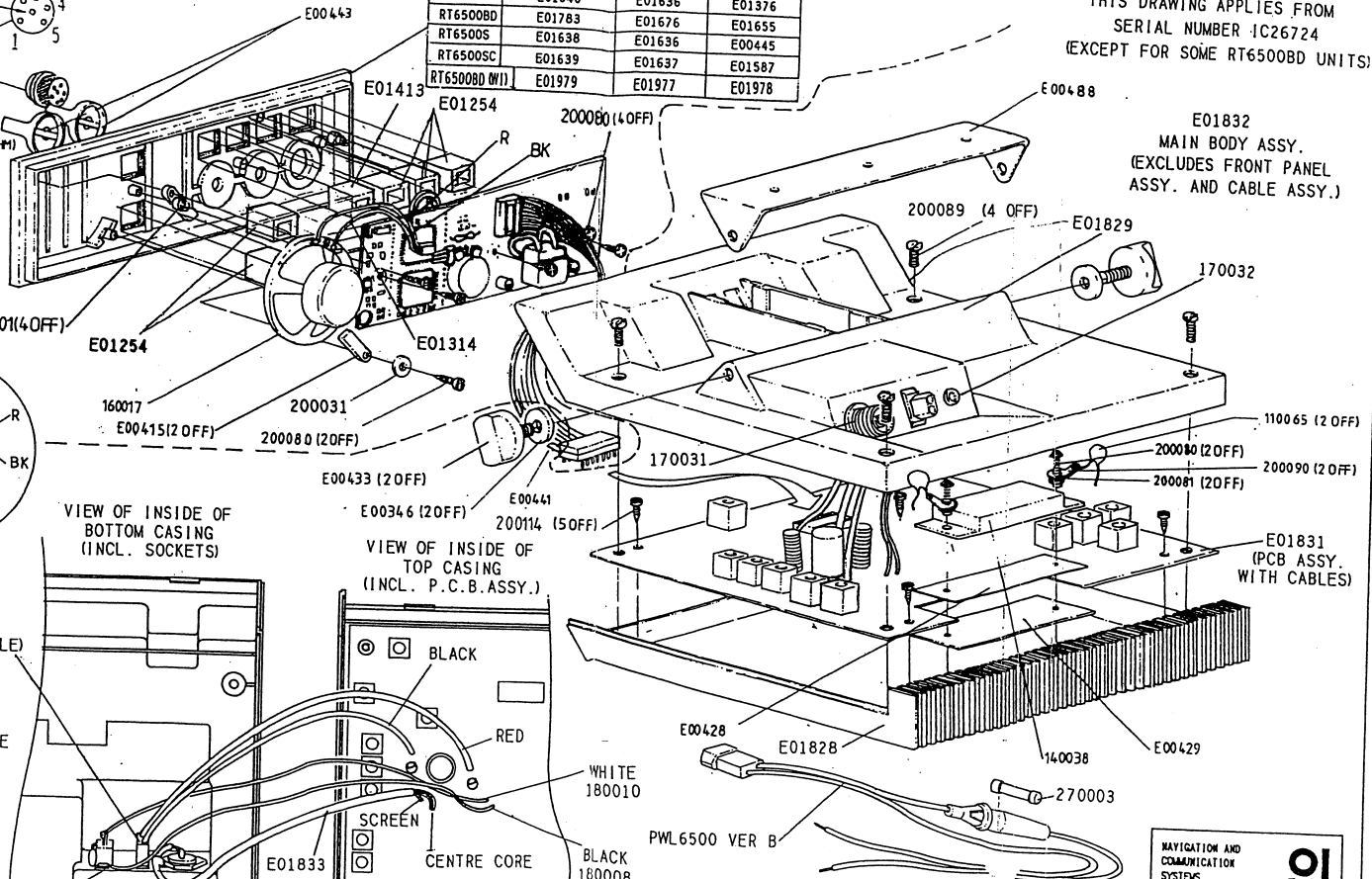

E01832
MAIN BODY ASSY.
(EXCLUDES FRONT PANEL
ASSY. AND CABLE ASSY.)

VIEW OF INSIDE OF
BOTTOM CASING
(INCL. SOCKETS)

VIEW OF INSIDE OF
TOP CASING
(INCL. P.C.B. ASSY.)

E01834
(SOCKET AND CABLE)

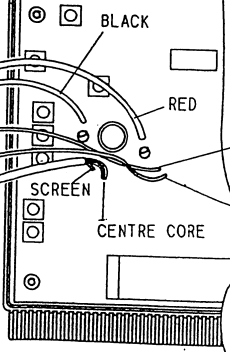
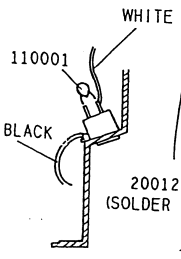

CHECKED
DATE
APPROVED
DATE

DRAWING No. E01937-
ASSEMBLY : RT6500/S/B/BD/SC
MODEL : RT6500.... VER B
ISSUE : 2

NAVIGATION AND
COMMUNICATION
SYSTEMS

NAVICO
STAR LANE
MARGATE
KEAT CT9 4NP

TEL 08431 290290
+ 44 843 290290
TELEX 965093 NAVICO G



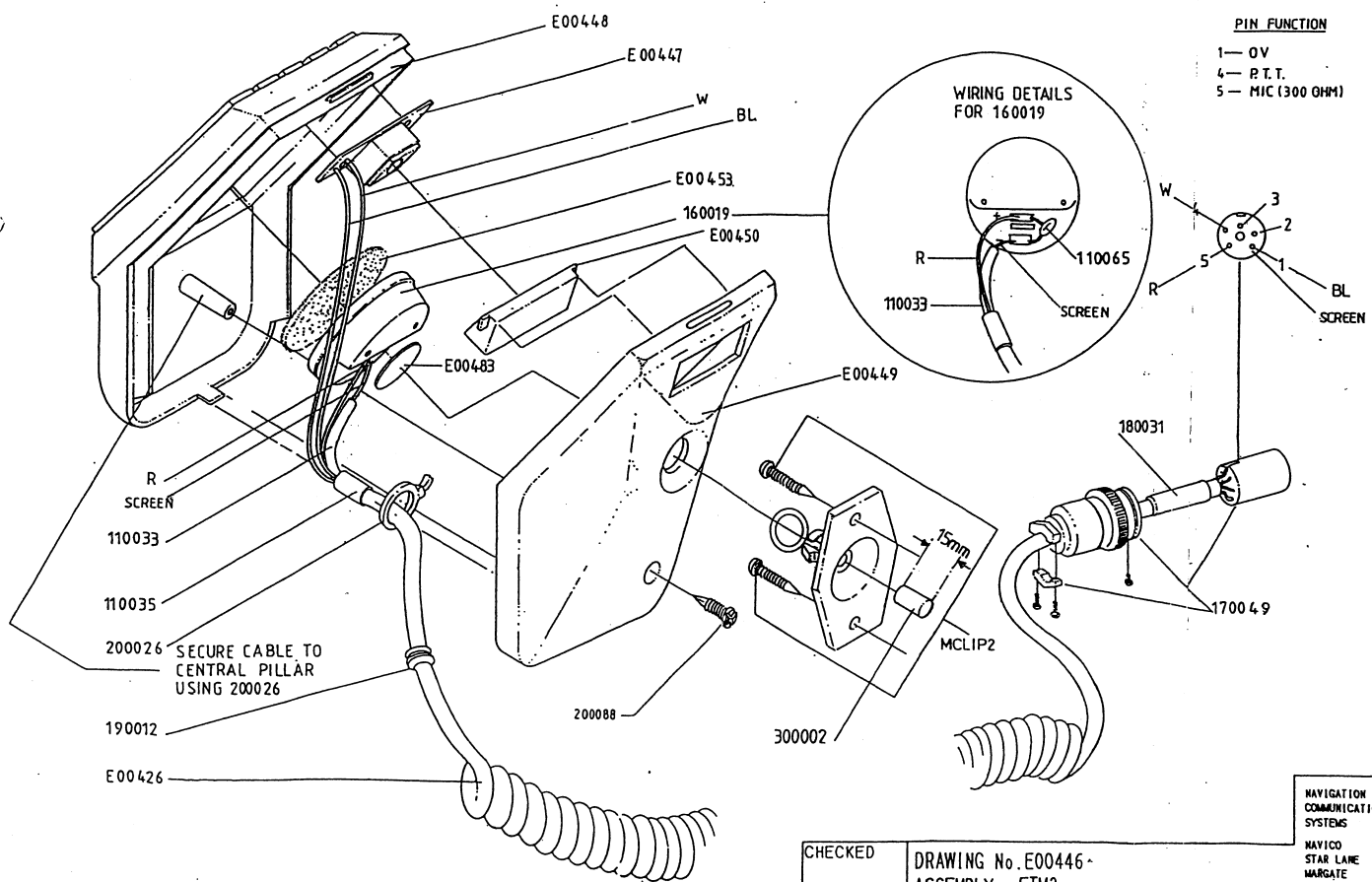

CHECKED	DRAWING No. E00446
DATE	ASSEMBLY : FTM2
APPROVED	MODEL : F1ST MIC
DATE	ISSUE : 3

NAVIGATION AND
COMMUNICATION
SYSTEMS

NAVICO
STAR LANE
MARGATE
KENT CT9 4NP

TEL 0843 290290
+ 44 843 290290
TELEX 965093 NAVICO G

NAVICO

FUNCTION

- 1 PHONES (300 OHM)
- 2 SPKR MUTE
- 3 P.T.T.
- 4 MIC (300 OHM)

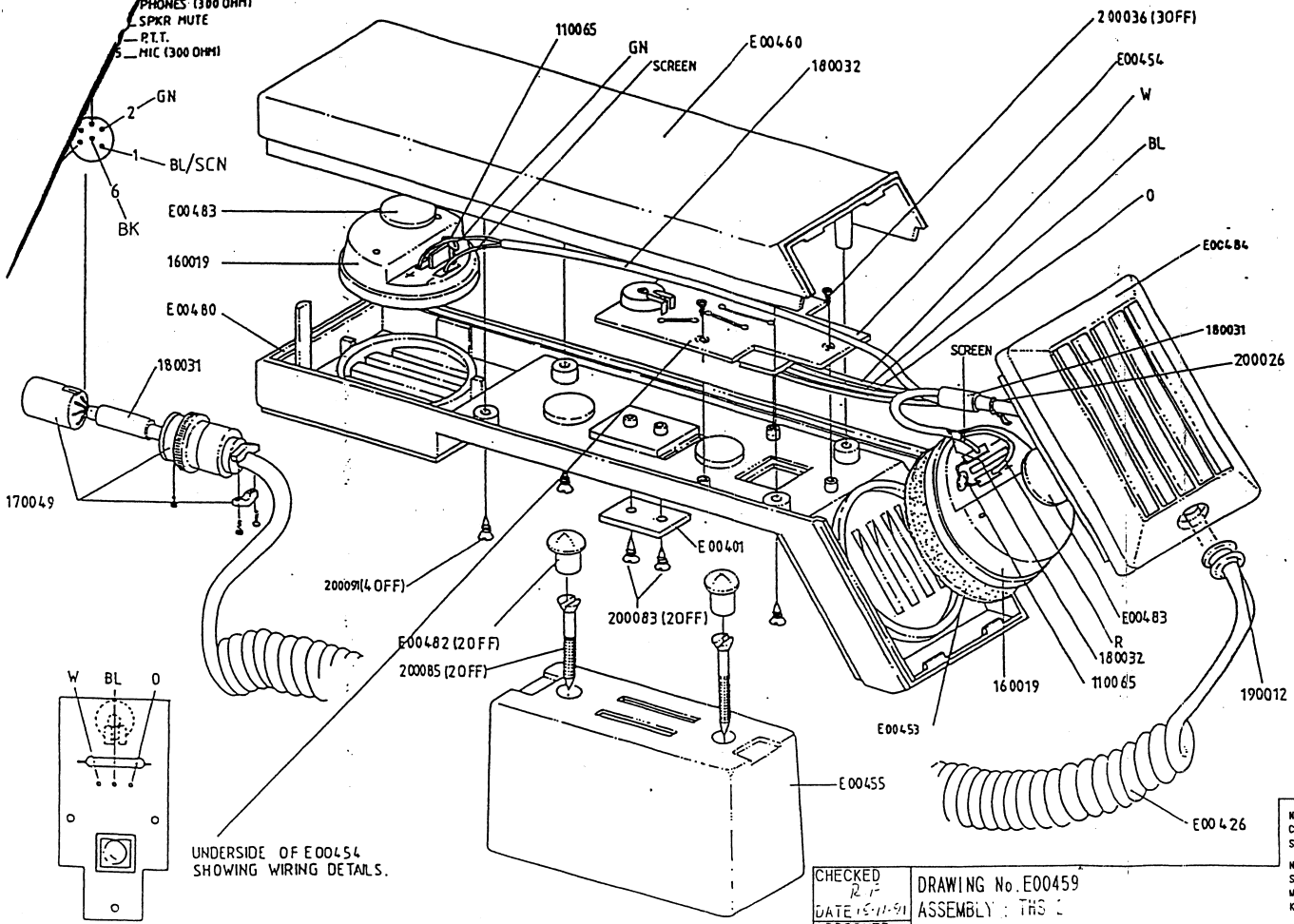

CHECKED
R-1
 DATE 15-11-91
 APPROVED
M-3
 DATE 18-11-91

DRAWING No. E00459
 ASSEMBLY : THS
 MODEL : TELEPHONE HANDSET
 ISSUE : 2

NAVIGATION AND COMMUNICATION SYSTEMS
 NAVICO
 STAR LAKE
 MARGATE
 KENT CT5 4NH
 TEL (0843) 290290
 FAX 0843 290290
 TELEX 965093 NAVICO G



CIRCULAR CONNECTOR

PIN FUNCTION

- 1: 0V
- 2: PHONE (300Ω)
- 3: SPEAKER MUTE
- 4: P.T.T.
- 5: MIC (300Ω)
- 6: +12V

VIEW FROM REAR OF CONNECTOR

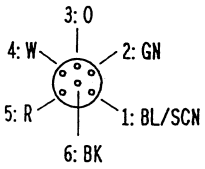

CONNECTOR TERMINAL

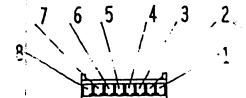

TERMINAL	WIRE COLOUR	FUNCTION
1	BLACK	+12V
2	ORANGE	SPEAKER MUTE
3	WHITE	P.T.T.
4	BLUE	0V
5	GREEN	PHONES
6	RED	MIC
7	SCREEN	0V
8	N/C	-

POSITIONS OF TERMINALS ON UNDERSIDE OF PCB FOR LOCATION OF CONNECTORS

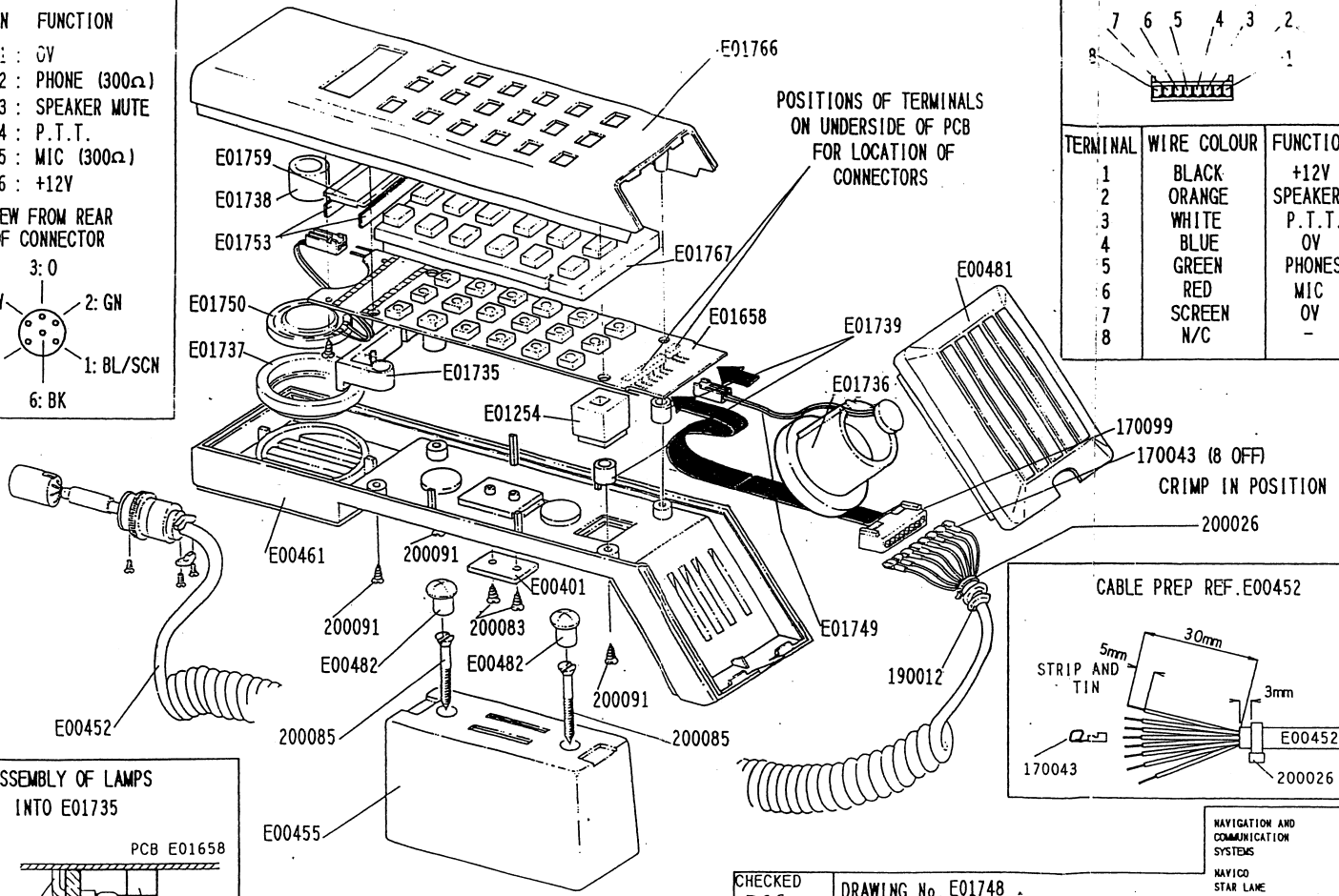

ASSEMBLY OF LAMPS INTO E01735

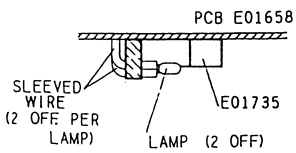

CABLE PREP REF. E00452

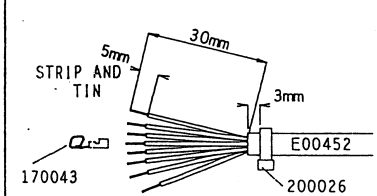

CHECKED
D.C.S.
DATE 4-1-92
APPROVED
A.W.
DATE 4-1-92

DRAWING No. E01748
ASSEMBLY : BD6500
MODEL : BD6500
ISSUE : 1

NAVIGATION AND COMMUNICATION SYSTEMS

NAVICO
STAR LANE
MARGATE
KENT CT9 4NP
TEL 0843 290290
+ 44 843 290290
TELEX 965093 NAVICO G

NAVICO

